



## 1. APPLICATION

Use in applications of steel cylinders (containers, trailers, bundles) production according to ISO 9809-1, ISO 9809-2 and AD 2000.

The cylinder's supplied for high pressure carbon dioxide systems are manufactured in accordance with European standards.

The cylinders comes with a standard color coded RAL 7037 painted, upon request also cylinders can be delivered with different color codes painted.

Detailed information has given in this documentation.



GENERAL INFORMATION	
BRAND	ALMAR
TYPE	10 ltr ; Ø 140 mm
CYLINDERS MEET THE REQUIREMENTS OF	ADR:2019; ISO 9809-1 i Dyrektywy 2010/35/EU
TEST PRESSURE	250 [bar]
TARE	~12 [kg]
MATERIAL	34CrMo4
GAS	CO <sub>2</sub>
MIN. CYLINDRICAL WALL THICKNESS	2,5 [mm]
UTMOST WEIGHT OF FILLING	6,7 [kg]
HEAT TREATMENT	H840-900 O570-630 [°C]

Table 1.1 GENERAL INFORMATION OF 2L CO<sub>2</sub> CYLINDER

## 2. INSTALLATION

During installation cylinders must fastening as seen as project drawing which given by ALMAR.

## 3. MECHANICAL PROPERTIES

For other mechanical details please see table 3.1 below.

MECHANICAL PROPERTIES	
Specified mechanical properties	Re min 755 [N/mm <sup>2</sup> ]; Rm 890-1099 [N/mm <sup>2</sup> ]; As 14 [%]
Thread test	25E PN EN ISO 11363-1
Hydraulic Test	250 [bar]
Hardness test	255-335 [HB]
Pneumatic test	... [bar]

Table 3.1 MECHANICAL PROPERTIES OF 10L CO<sub>2</sub> CYLINDER

Note: The cylinders were stamped with the mark of conformity pi



#### 4. MAINTANANCE

If the fixed CO2 cylinders are found to be in a very good condition at the 10 year interval, then the MCA will accept the hydrostatic test requirements specified in MSC/Circular 1318 paragraph 6.1.2, provided.

If any CO2 cylinders are found to be in a poor condition, (rusty, damaged, etc.), at the 10 year interval, then the MCA would insist that

Annual inspections (MSC/Circular 1318 paragraph 5) it is recommended that this is performed by persons specially trained in the maintenance of such systems, e.g. manufacturer or recognised service company.

Full maintenance (Circular 1318 paragraph 6) - should be performed by persons specially trained in the maintenance of such systems, e.g. manufacturer or recognised service company.

#### 5. CERTIFICATION

When it's necessary the following certificates can be issued :

- a. TYPE APPROVAL CERTIFICATE
- b. TÜV
- c. .II CERTIFICATE
- d. INSPECTION CERTIFICATE'S ( RUSSIAN MARITIME REGISTER of SHIPPING, BUREAU VERITAS, LLOYD'S REGISTER, etc.)

#### 6. ACCESSORIES

All cylinders comes with required type valve and protect cap.

- I. AUTOMATIC VALVE (Figure 6.1)
- II. VALVE (Figure 6.2)
- III. CAP (Figure 6.3)



Figure 6.1



Figure 6.2

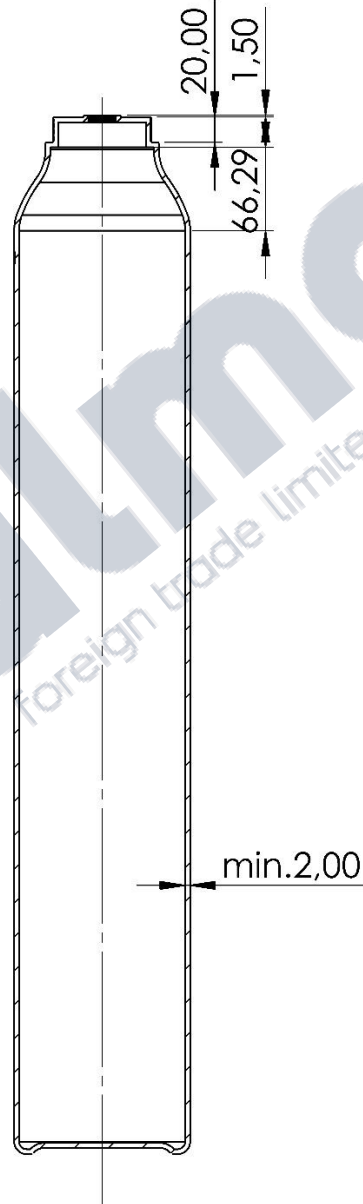
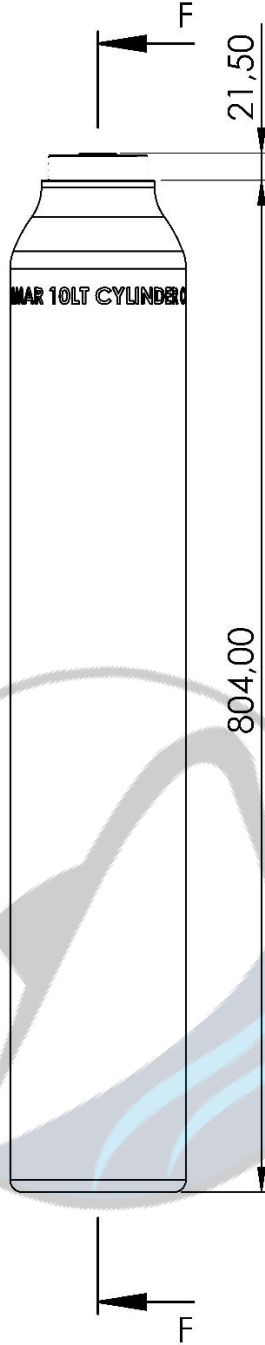
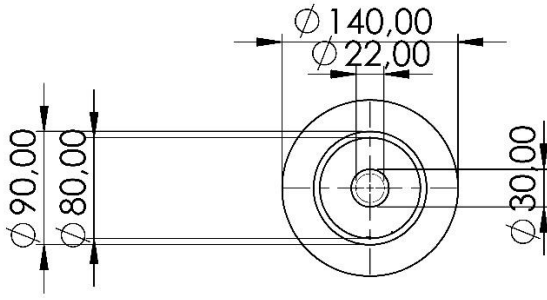

Figure 6.3

#### 7. DIMENSIONS & TECHNICAL DRAWINGS

For detailed technical drawings please see following page.

# 10L CYLINDER



**COMMENT:** CO2 Cylinder comes fastened with related valve and filled. Please see Datasheet AT.20-40009Rev01 for more detail.  
**NOTE:** ALL DIMENSIONS ARE GIVEN AS MILLIMETERS

DRAWING NO:	POS. NO. 1B	PROODUCT NO: AT.20-40010	DATASHEET: AT.20-40010Rev00	PAGE A4
DESIGNED BY: ALİ ARMAĞAN	CHEKED BY: ÇAĞLAR LATİFOĞLU	APPROVED BY: ERDİNÇ LATİFOĞLU	DATE: 11/09/2020	SCALE: 1:6
		PROJECT / PROODUCT: 10L CO2 CYLINDER		
		WEIGHT: 6.7 KG	METARIAL: 34crmo4	REVISION: Rev00

## THE CYLINDER MANUAL INSTRUCTION OF USAGE AND EXPLOITATION

Seamless steel gas refillable cylinders are the pressure vessels designed and manufactured for a storage of compressed and liquefied under pressure gasses.

### GENERAL RECOMENDATIONS

- I. It is necessary to know this manual instruction and to keep its requirements.
- II. Devices, which are mentioned in this manual instruction should be used according to their destination.
- III. The producer is not responsible for damages caused by faulty exploitation, usage, storage and maintenance of gas cylinders.
- IV. The usage, filling, maintenance, service and the repair of cylinders for compressed gasses should be made by qualified and the competent personnel only. The personnel should be properly trained and should be authorized in accordance with regulations valid in the country of usage.
- V. In case when cylinders are serviced or repaired by people who have no proper knowledge or authorization corresponding to regulations valid in the country of usage or if cylinders are use in the way, which is against the rules of application, the responsibility for the proper functioning will carry over to the user
- VI. Any changes in the cylinder design should be made only after receiving a written permission from a cylinder producer.
- VII. In the case when any fault or damage of a new product is found, then this product should be put away, preserved and the producer should be informed immediately.

### USAGE

- I. The producer recommends the adaption of ADR European Agreement, which is related to the international transport of dangerous goods
- II. Containers, hampers, pallets or similar methods of cylinder transportation, which ensure avoiding of unacceptable damage and contamination should be used for transportation of cylinders.
- III. Valves protection devices (for example protection caps) should be obligatory used during the cylinder transportation
- IV. Dropping cylinders, uplifting cylinders with using valve, rolling it in a horizontal position is unacceptable during the transportation operations.
- V. Filling cylinders with a gas should be made only by companies or people who have proper authorizations issued according to regulations, rules and standards valid in the country of usage..

- VI. Cylinders should be equipped with, valve and connections with a recommended test pressure. Elements, connections and valve should have necessary approvals made according to regulations, rules and standards valid in the country of usage.
- VII. Valves should be fitted according to regulations, rules and standards valid in the country of usage.
- VIII. Sealing materials according to EN ISO 11114-2 Standard, should be used in order to seal a valve in cylinder neck. If it is necessary a producer recommends a usage of PTFE teflon tape with a min. thickness 0.1mm.

### PRESERVATION AND STORAGE

- I. The storage of pressure cylinders, both filled or empty, is permitted under the roof only - cylinders should be protected against a direct exposure of harmful weather conditions (rain, snow, solar radiation etc.)
- II. Keep cylinders far from the open fire, protect them against a direct exposure of the aggressive environment and chemicals
- III. During the storage, cylinders should be protected against mechanical damage, falls and mechanical contamination.
- IV. Cylinders should not be kept in underground chambers, on stairs or close to stairs, in corridors, crossings and garages.

### SERVICE

- I. To detect eventual outside damage, the producer recommends to carry out of a visual inspection during each cylinder filling.
- II. Cylinders should be submitted to systematic periodical inspections according to regulations, rules and standards valid in the country of their usage. Inspections should be carried out by authorities which supervise pressure devices in the country of usage according to rules and law regulations of particular country.

### NOTES DEFINITLY IT IS FORBIDDEN TO USE CYLINDERS,

- I. IN OTHER PURPOSE THAN IT IS DETERMINED IN A VALID APPROVAL
- II. WHEN CYLINDERS HAVE EXCEED THE DATE OF THE NEXT INSPECTION
- III. WHEN CYLINDERS HAVE EXCEED THE DATE OF THE NEXT INSPECTION
- IV. WHICH HAVE VISIBLE FAULT, DAMAGE OF CYLINDER BODY, DAMAGE OF VALVES, CONNECTIONS AND OTHER DAMAGE
- V. WHICH HAVE DAMAGED OR LEAKING EQUIPMENT
- VI. TO MAKE OILING AND GREAINING OF VALVES AND OTHER PARTS OF CYLINDERS.