



almar
foreign trade limited company

Flashni

Xenon Sounder Beacon

Datasheet Version 1.1



0.7J, 103/101dB(A)

Up to IP65

32 tones

Red/Amber/Blue/Green/Clear

Audio visual
signalling



Tel: +44(0)1252 725257

Fax: +44(0)1252 727627

© 2018/19 LGM Products Ltd.

Email: sales@lgmproducts.com

Web: www.lgmproducts.com

ISO 9001:2015 certified

Address: LGM Products Ltd, Unit 15 Riverside Industrial Park, Farnham, Surrey, GU9 7UG, United Kingdom.



almar
foreign trade limited company

Flashni Xenon Sounder Beacon

Datasheet Version 1.1

Sound output	12Vdc: 103dB(A) 24Vdc: 101bB(A)
Alarm tones	32
Sounder current	12Vdc: 110mA 24Vdc: 68mA
Volume control	10dB(A)
Light output	0.7J Xenon bulb
Flash rate	1Hz
IP rating	IP54 (shallow base) IP65 (deep base)
Voltage	9-15Vdc (12Vdc version) 18-28Vdc (24Vdc version)
Unit weight	0.33kg
Temperature	-10°C to +55°C
Unit material	ABS. Polycarbonate lens
Light colour	Red/Amber/Blue/Green/Clear
Unit colour	Red/White
Approvals	EN54-3 compliant Vds

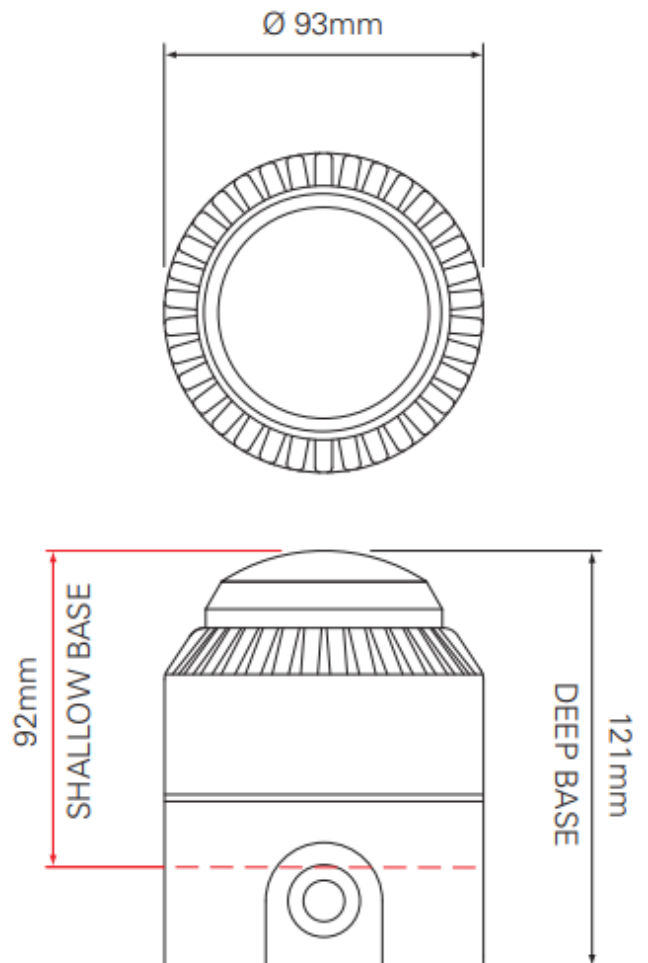

Shallow Base, Deep Base, U Base and
Powered Deep Base options available

Tel: +44(0)1252 725257

Fax: +44(0)1252 727627

© 2018/19 LGM Products Ltd.

Email: sales@lgmproducts.com

Web: www.lgmproducts.com

ISO 9001:2015 certified

Address: LGM Products Ltd, Unit 15 Riverside Industrial Park, Farnham, Surrey, GU9 7UG, United Kingdom.